

PAPER • OPEN ACCESS

Design of a new gas-dynamic stabilization system for a metal-cutting plasma torch

To cite this article: I Yu Matushkina *et al* 2021 *J. Phys.: Conf. Ser.* **2094** 042075

View the [article online](#) for updates and enhancements.

You may also like

- [Experimental study on the jet characteristics of a steam plasma torch](#)
Fangyuan LIU, , Deping YU *et al.*
- [Effect of a gas-vortex stabilization method on the kinematic properties of the jet in metal-cutting plasmotrons](#)
S V Anakhov, A V Matushkin and Yu A Pyckin
- [Comparative analysis of the arc characteristics inside the converging-diverging and cylindrical plasma torches](#)
Jianghong SUN, , Surong SUN *et al.*



IOP | ebooks™

Bringing together innovative digital publishing with leading authors from the global scientific community.

Start exploring the collection—download the first chapter of every title for free.

Design of a new gas-dynamic stabilization system for a metal-cutting plasma torch

I Yu Matushkina¹, S V Anakhov² and Yu A Pyckin³

¹ Welding technology chamber, Ural Federal University, 19, Mira str., Yekaterinburg, 620078, Russia,

² Physics and mathematics chamber, Russian State Vocational Professional University, 11, Mashinostroiteley, Yekaterinburg, 620012, Russia,

³ Physical and chemical technologies of biosphere protection chamber, Ural State Forest Engineering University, 37, Siberian tract, Yekaterinburg, 620038, Russia

E-mail: 227433@e1.ru

Abstract. The analysis of the influence of various design solutions of the gas-dynamic stabilization system in plasma torches for cutting metals on the efficiency of equalizing the velocities of gas flows along the cross-section of the gas path is carried out. It is noted that the efficiency evaluation method developed by the authors should be based on the calculation of the uniformity of the gas flow velocity distribution over the cross-section of the gas-air path of the plasma torch. A vortex stabilization system using two swirlers is proposed. The effect of improving the reliability and quality of plasma cutting is shown. The results of the efficiency studies for the proposed system of gas-vortex stabilization in metal-cutting plasma torches are presented. The calculating results of equalization coefficients for the velocity distribution in different parts of the gas-dynamic stabilization system in the plasma torch are presented. Based on the results of the calculations, a constructive optimization of the gas-air path in the plasma torch was performed. The experimentally obtained advantages of the new upgraded plasma torch in terms of the gas-vortex stabilization efficiency are demonstrated. The effects of improved cutting quality and reduced nozzle wear in the new plasma torch are shown. This is due to the higher degree of the plasma arc stabilization in the new plasma torch, which leads to a decrease in its oscillations, and, consequently, to an increase in the efficiency of the cutting process.

1. Introduction

Plasma cutting of metals is one of the most popular procurement technologies in mechanical engineering [1]. The high efficiency of its application for almost any range of steels in a wide range of thicknesses is largely determined by the operating parameters of the main technological element – the plasma torch. Unfortunately, most of the plasma torches on the market of domestic production are currently inferior in terms of performance, cutting quality and energy efficiency to the best samples of foreign production. This circumstance makes the task of finding new design solutions one of the most relevant for Russian designers of plasma equipment [2].

In previous studies, the authors of this article showed that the efficiency of metal-cutting plasma torches largely depends on the organization of the gas-dynamic stabilization (GDS) system for the plasma arc (jet) [3]. The single-flow (single-circuit) GDS system used in most plasma torches relies on a gas-vortex stabilization method based on the use of a single swirler followed by compression of the



plasma arc by a vortex flow of plasma-forming gas (PFG) by the walls of the plasma torch nozzle [4]. However, the unevenness of the gas supply to the swirler leads to an uneven distribution of the PFG flow parameters in the plasma torch nozzle, thereby causing instability of the arc (jet) parameters, and, consequently, the parameters of the plasma cutting efficiency (cutting quality, reliability, etc.) [5]. To solve this problem, the authors proposed several design options for organizing the GDS system in plasma torches, one of which is analyzed in this paper.

This paper shows the process of optimizing the GAP design of the single-flow metal-cutting plasma torch developed by the authors, which differs from most conventional schemes by the symmetrical gas supply to the GDS system, as well as by the use of 2 swirlers (preliminary and main) and 2 sections of the PFG flow equalization. In addition to the gas-dynamic criteria, such task must also be solved by taking into account the requirements of material consumption and manufacturability for plasma torches.

2. Technique of researches

Considering the gas flow velocity as one of the key parameters determining the operation of the GDS system [6], the authors introduced the velocity uniformity parameters that determine the stability of its distribution in the control sections of the gas-air path (GAP) in the plasma torch. It was previously shown [7] that the following criteria can be selected: the ratio between the maximum and minimum velocity values (the ratio of variation) L , the average linear deviation a of the velocity values along the median cross-section line, the mean square deviation S and the coefficient of speed variation F . The velocities themselves were determined in the process of the gas-dynamic parameters numerical simulation in the GAP of the plasma torch 3D model in the FlowWorks application of the SolidWorks software (the degree of sampling is from 200 to 900 calculated points per control cross-section line). As a key parameter determining the operation of the GDS system, the velocity variation coefficient F was used.

Figure 1 shows the GAP of a single-flow metal-cutting plasma torch developed by the authors, which provides the equalization of the PFG flow and the maximum efficiency of the GDS system due to the layout of GAP individual sections. The design of this plasma torch GAP differs from most conventional schemes by the symmetrical gas supply to the GDS system, as well as the use of 2 swirlers (preliminary and main) and 2 sections of the PFG flow equalization.

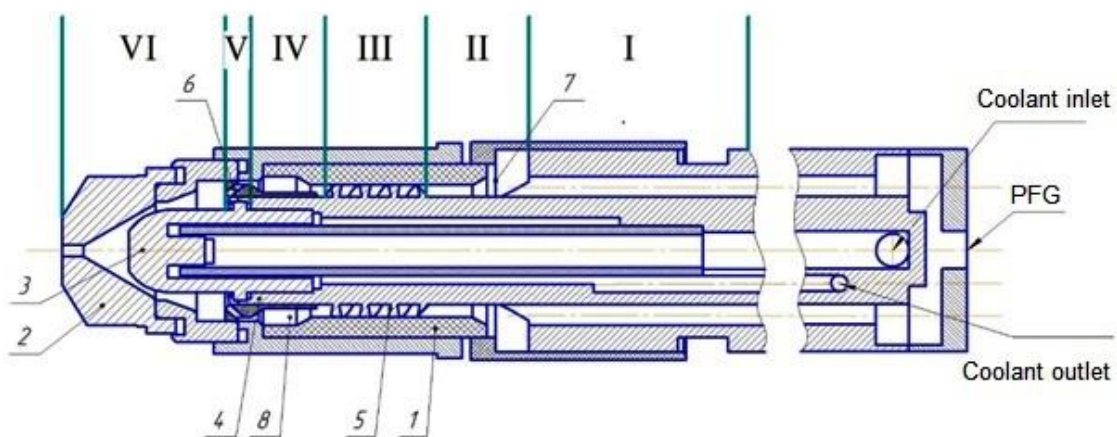

Figure 1. Design diagram of the plasma torch. Plasma torch elements: 1 – insulator, 2 – nozzle, 3 – cathode, 4 – electrode holder, 5 – preliminary (forming) swirler, 6 – main (stabilizing) swirler, 7 – 1st expansion (mixing) chamber, 8 – 2nd expansion (stabilizing) chamber. GAP sections: I – PFG feed, II – pre-flow equalization, III – pre-swirl, IV – main flow equalization, V – main swirl, VI – nozzle assembly. PFG – plasma-forming gas.

Consider the 3 stages of solving the design problem in creating a plasma torch with the most efficient GDS system.

At the first stage, the length of the pre-flow equalization section was determined (before the pre-swirler – figures 1 and 2). The analysis of the equalization of the PFG flow along the cross-section was carried out. The analyzed section was after PFG outlet from 2 symmetrically arranged holes with an inclination relative to the axis of the plasma torch in the range from 60° to 70° into the annular cavity of section. According to the results of the gas-dynamic criteria calculations, a stable tendency of the PFG flow equalization was established, which made it possible to determine the location of the preliminary swirler at a distance of 6-8 mm from the point of the PFG input into the 1st expansion chamber.

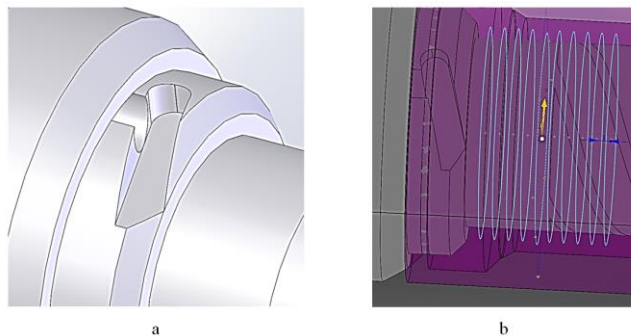

Figure 2. Gas supply scheme (a) with the PFG distribution and velocity calculation (b) at the GAP section of the pre-flow equalization (II).

The second stage of design optimization was the determination of the length of the main flow equalization section (the distance between the preliminary and main swirlers of the plasma torch GAP (figures 1 and 3)) – the 2nd expansion chamber. For this purpose, the efficiency of the PFG flow equalization along the chamber cross-section after its outlet from 4 symmetrically arranged rectangular grooves (with an inclination relative to the axis of the plasma torch in the range from 60° to 70°) of the preliminary swirler into the annular cavity of the 2nd expansion chamber was determined. According to the results of the calculations, the tendency of the PFG flow equalization with a higher efficiency than in the 1st expansion chamber was revealed and the optimal distance of 8-12 mm from the output of the pre-swirler for the placement of the main swirler was determined.

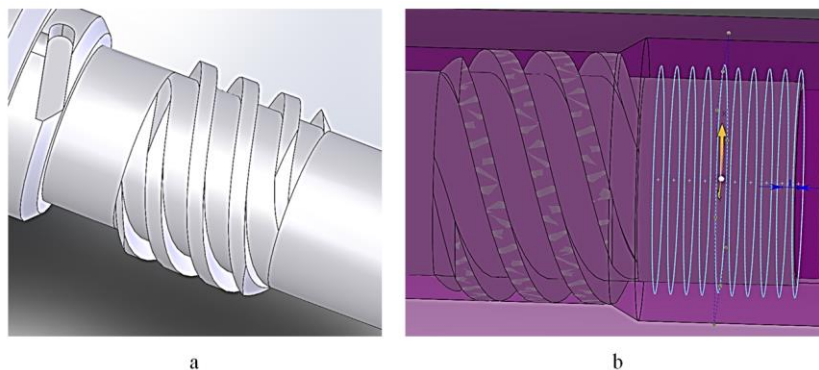

Figure 3. Gas flow scheme (a) with the PFG distribution and velocity calculation (b) at the main GAP section of flow equalization (IV).

The next stage of development was to check the effectiveness of the GDS system. The analysis of the PFG flow equalization along the cross-section of the GAP channel after the PFG outlet from the symmetrically located holes of the main swirler (figure 4) into the annular cavity was performed. The number of holes can vary from 8 to 16 depending on the cutting current, and the slope relative to the axis of the plasma torch – from 60° to 70° . Calculations have shown that, starting from 5 mm from the point of the PFG inlet, the value characterizing the degree of velocity equalization along the cross-section decreases below 0.1. Taking into account the fact that the cathode end is located at a distance of 6-7 mm from the outlet of the swirler holes, it can be concluded that the arc is reliably stabilized on the electrode surface.

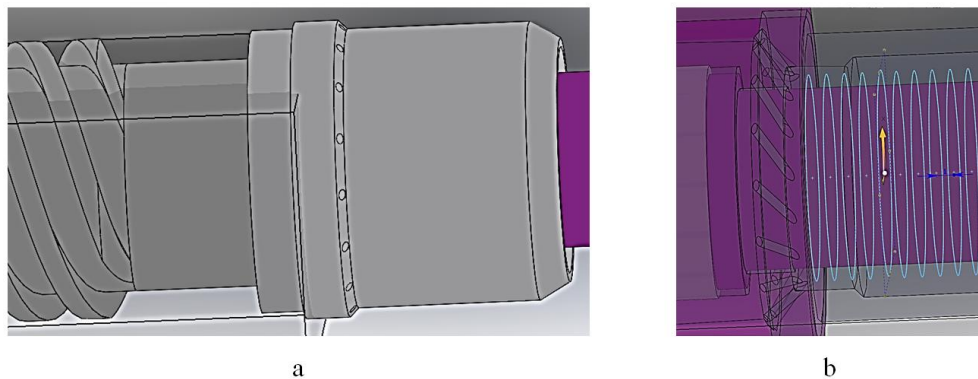

Figure 4. Gas flow scheme (a) with the PFG distribution and velocity calculation (b) at GAP section of gas supply from the main swirler to the nozzle (V and VI).

3. Results of research and their discussion

Figure 5 shows a comparative graph of the change in the coefficient of velocity variation F ($F=S/\langle V \rangle$, where S is the average square deviation of the velocity, $\langle V \rangle$ is the average value of the velocity in the section of the GAP), depending on the distance from the gas input point in the GAP sections considered above. The analysis of the presented data shows the effectiveness of the developed GDS system, which provides an increase in the uniformity of the velocity distribution by about 70 times (from the initial to the final points of the calculated part of the GAP). At the same time, if at the 1st stage of the analysis (the 1st expansion chamber) the coefficient F decreases by about 4 times, at the 2nd stage (the 2nd expansion chamber) – by 18 times, then at the 3rd stage (the section of gas supply from the main swirler to the nozzle) there is a high degree of both flow stabilization along the length and in the section of the GAP. In addition, the considered design provides an increase in the average gas velocity $\langle V \rangle$ from 25-30 m/s at the 1st stage, to 100-110 m/s at the stage of gas input to the part of its heating by a plasma arc, followed by compression and acceleration in the nozzle of the plasma torch.

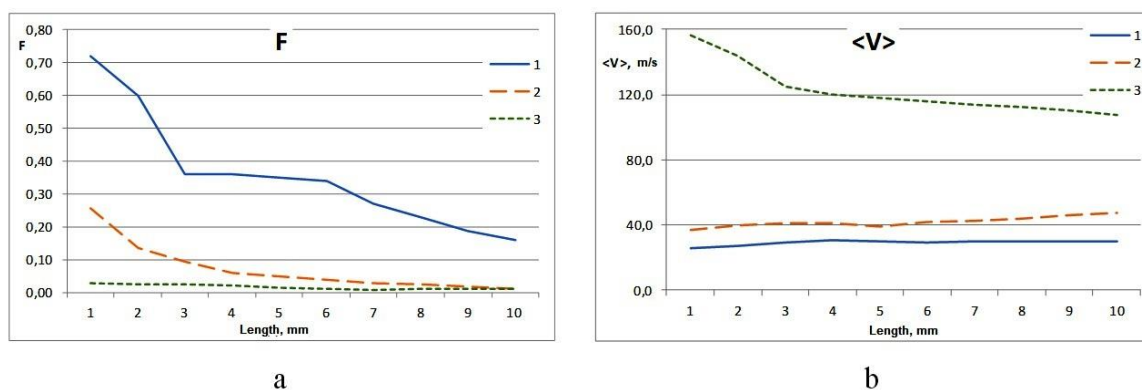

Figure 5. Graph of the change in the coefficient of the velocity variation F (a) and the average velocity $\langle V \rangle$ at a distance from the gas input point (1 – in section II, 2 – in section IV, 3 – in sections V and VI).

Figure 6 shows a pilot model of a single-flow plasma torch PMVR-5.3 (manufacturer – LLC "Polygon", Ekaterinburg) for precision cutting of small and medium thickness metals with a design optimized according to the described scheme.



Figure 6. Pilot model of the plasma torch PMVR-5.3 for precision cutting of small and medium thickness metals.

The tests of this plasma torch showed less wear of the working surfaces of the cathodes. Test modes – 200 turns on each with a total cutting length of 120 meters. Cutting was performed on St30Ps steel with the following parameters of the plasma torch operation: cutting current – 120 A; cutting voltage ~180 V; PFG pressure ~ 4.5 atm.; nozzle diameter – 1.9 mm; plasma torch reach – 6-7 mm. The cutting speed was 1.5 m/min with a steel thickness of 10 mm. The figure 7 shows a clear location and outline of the cathode spot in the center of the cathode surface in comparison with the basic model – the PMVR-M [5] plasma torch (GDS with a single swirler and an asymmetric input of the PFG into the expansion chamber). In addition, in the plasma torch PVMR-5.3 a more uniform wear of the nozzle was observed on both the outer and inner surfaces. At the same time, the cylindrical shape of the central nozzle hole was preserved in comparison with the basic model. These results obviously indicate an increase in the efficiency of the PFG flow stabilization achieved in the nozzle assembly of the PMVR-5.3 plasma torch.

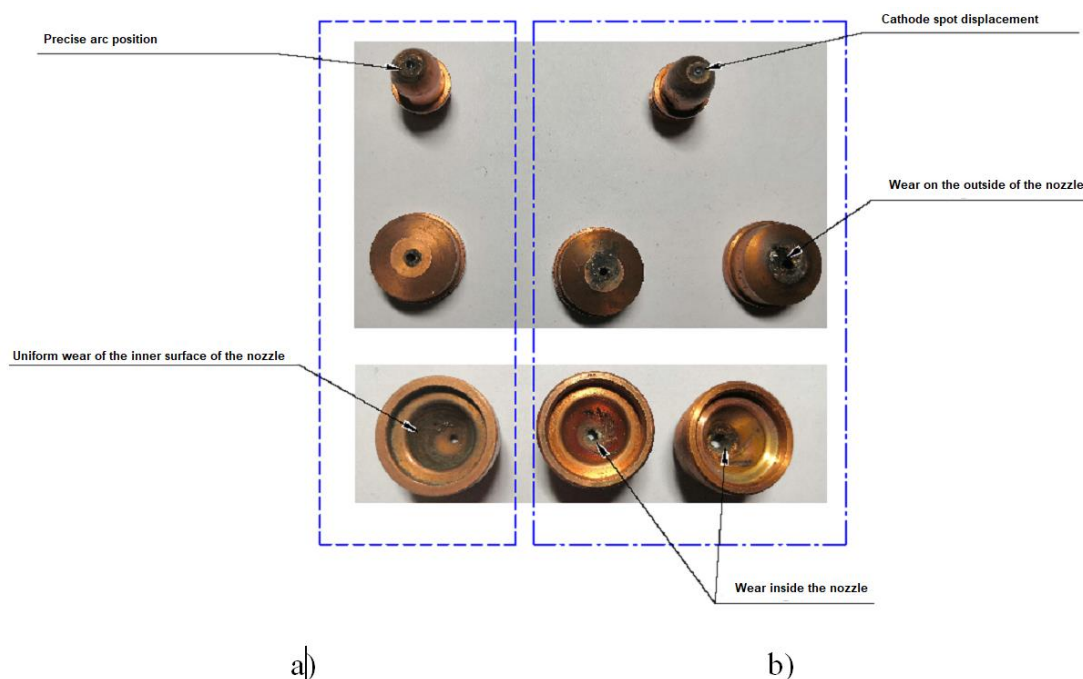

Figure 7. Analysis of the wear for the working surfaces of the nozzle-cathode sets during operation: a – new plasmatron PMVR-5.3, b – basic plasma torch PMVR-M.

The effectiveness of the developed GDS system is also evidenced by the results of practical tests of plasma torches on the quality of the cut shown in figures 8, a and b. The figures clearly show that the cut surface obtained using the new plasma torch PMVR-5.3 is uniform with a low level of surface roughness, and when cutting with a basic plasma torch, there is an uneven surface of the cut with alternating sections with a low increased level of surface roughness. The shown effect is explained by a lower degree of the plasma arc stabilization in the base plasma torch, which leads to increased fluctuations, and, consequently, to a decrease in the quality of the cut surface.

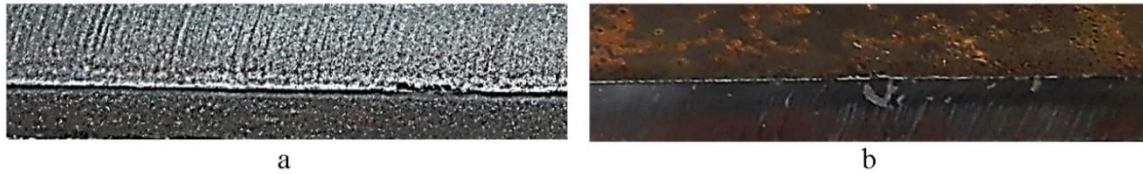

Figure 8. Quality of plasma cutting (St30Ps steel, sample thickness 10 mm): a –with PMVR-M base plasma torch, b – with PMVR-5.3 plasma torch.

4. Conclusions

In this paper the method of the GDS system designing based on gas-dynamic criteria was presented. This method allows us to develop metal-cutting plasma torches with more effective indicators of productivity, reliability and cutting quality. The developed plasma torch with an optimized GDS design using 2 swirlers has a high potential for implementation in the segment of plasma cutting technologies for metals of small and medium thicknesses.

References

- [1] Cherednichenko V, Anshakov A and Kuzmin M 2011 *Plasma electrotechnological installations* (Novosibirsk: NGTU) p 602
- [2] Anakhov S 2018 *Principles and methods of plasma torches designing* (Ekaterinburg: RSVPU) p 165
- [3] Anakhov S, Pykin Yu, Matushkin A and Shakurov S 2011 *Welding production* **12** 10-5
- [4] Zhukov M and Anshakov A 1979 *The basis of the calculation of the linear plasma torches schema* (Novosibirsk: ITP SB AS USSR) p 146
- [5] Anakhov S, Pykin Yu and Matushkin A *Welding International* **30(4)** 310-4
- [6] Abramovich G 1991 *Applied gas dynamics Part 1* (Moscow: Nauka) p 597
- [7] Anakhov S, Pykin Yu and Matushkin A 2018 *Bulletin PNIPU* **20(3)** 29-37