

PAPER • OPEN ACCESS

Temperature influence on the effectiveness of gas-vortex stabilization in plasma torches

To cite this article: S V Anakhov *et al* 2018 *IOP Conf. Ser.: Mater. Sci. Eng.* **441** 012006

View the [article online](#) for updates and enhancements.



IOP | ebooksTM

Bringing you innovative digital publishing with leading voices to create your essential collection of books in STEM research.

Start exploring the collection - download the first chapter of every title for free.

Temperature influence on the effectiveness of gas-vortex stabilization in plasma torches

S V Anakhov ^{1,a*}, Yu A Pyckin ^{2,b}, A V Matushkin ^{3,c}

¹Russian State Vocational Professional University, Physics and mathematics chamber, 620012 Russia, Yekaterinburg, Mashinostroiteley 11

²Ural State Forest Engineering University, Physical and chemical technologies of biosphere protection chamber, 620038, Yekaterinburg, Siberian tract, 37

³Ural Federal University, Welding technology chamber, 620078 Russia, Yekaterinburg, Mira str., 19

^a email: sergej.anahov@rsvpu.ru, ^b email: yappoligon@mail.ru, ^c email: 227433@e1.ru

Abstract. The results of the efficiency studies of gas-vortex stabilization systems for metal-cutting plasmatrons are presented. It is noted that the method of efficiency evaluation developed by the authors should be based on the calculation of the uniformity of the gas flow velocity distribution over the section of the gas-heating path of the plasma torch. Various simplified and accurate estimation methods are proposed. The results of calculation of the velocity distribution in the control section for different modifications of plasma torches are presented. Calculations are made on the "cold" model gas flow and its heating by a plasma arc. It is shown that when heated by a plasma arc, the flow rate at the inlet to the nozzle channel of the plasma torch and the degree of irregularity of the velocity distribution in the control section increase. By methods of statistical analysis the main parameter of the effectiveness evaluation of individual gaseous-vortex stabilization was chosen – criterion of the velocity variations. Demonstrated the advantages of the new upgraded torches, including working on technology narrow jet plasma, from the point of view of the effectiveness of gas-vortex stabilization.

1. Introduction

As shown by the authors [1], the development of high-precision plasma cutting technologies should be carried out taking into account the gas-dynamic features of the plasma-forming gas (PFG) flow, which determine the efficiency, quality and safety of the plasma torch. Based on the results of the authors' analysis of the gas-dynamic features of the gas flow through the gas-air path (GAP) of plasma torches, the authors developed a method for evaluating the efficiency of gas-vortex stabilization systems of the plasma arc [2]. This method bases on the use of automated procedures to determine the criterion of the uniformity of the flow velocity distribution through the cross section of GAP channels. However, the previously presented results of the application of this technique were obtained taking into account the minimum effect of the gas-dynamic flow heating by plasma arc in the nozzle unit of the plasma torch. However, a certain influence of the plasma arc on the PFG velocity in the control section selected at the inlet to the nozzle channel of the plasma torch must be present. In this regard, the authors set the task to assess the degree of this influence and the applicability of the previously proposed method. An additional task was the clarification of criteria of gas-vortex stabilization efficiency, derived using the automated procedures of dynamic analysis.

2. Technique of researches

As is known, a typical design of a GAP in metal-cutting plasma torch (Fig.1) includes a section of gas supply to the plasma torch, a sedative (expansion) chamber and a gas-vortex stabilization system (GVS), which provides a tangential supply of PFG from the swirler (vortex chamber) to the nozzle unit (electric arc chamber). The method is based on the determination of the uniformity of the flow velocity distribution over the GAP cross section in the electric arc chamber of the plasma torch as one of the main factors affecting the quality and reliability of the plasma torch. This condition, as shown earlier [2], is determined by the design features of GAP plasma torches with a single-flow scheme of the PFG flow and, as a rule, is not fulfilled due to asymmetric and lopsided gas supply to the expansion chamber of the plasma torch. The geometry of individual sections of GAP, as a whole, is the same for most of the known domestic plasmatrons (PVR-402, VPR-410), including the one taken as the basic for the research of the plasma torch PMVR-M.

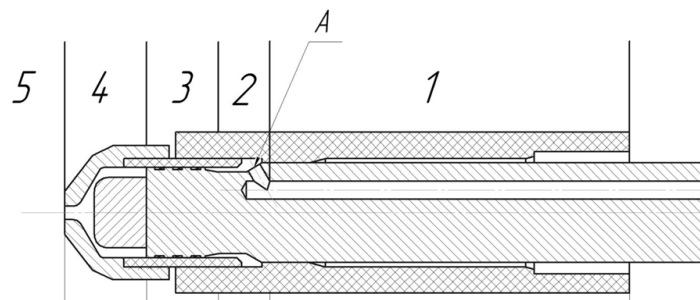

Figure 1. Scheme of air-gas path of metal-cutting plasmatron PMVR-M. Sections of GAP:

- 1 – PFG supply into the plasmatron, 2- expansion chamber, 3 – swirler, 4 – nozzle unit,
5 – plasma output, A – point of input of PFG into expansion chamber

To improve the uniformity of the flow distribution over the GAP, the authors proposed several design solutions [3]. One of them was implemented in the plasma torch PMVR-2M due to the use of a system of gas-dynamic filters (unbroken and perforated walls in the expansion chamber), as well as optimized by gas-dynamic criteria geometry of the expansion chamber and the swirler (Fig.2).

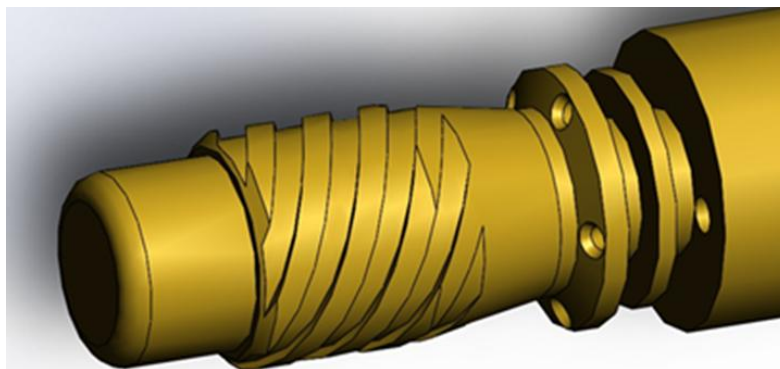

Figure 2. Scheme of the gas path in the plasma torch PMVR-2M with a system of gas-dynamic filters (unbroken and perforated walls in the expansion chamber)

Another effective solution was the development of the GAP design with symmetrical supply of PFG into the expansion chamber, 2 swirlers (forming and stabilizing) and 2 expansion chambers (Fig.3). Application of dynamic analysis methods allows to find the optimal size and location of expansion chambers and swirlers and to show the effectiveness of individual gas-vortex stabilization when using

this design at the "cold" (without taking into account plasma heating by the arc) flow of PFG. Such method of the velocity equalization can be applied in the plasma torches with both two- and single-flow scheme of the PFG flow organization. In the first case, the considered GVS technology may be used in the forming jet channel of a plasma torch, operating on the principle of a double nozzle and in various embodiments, having the name "narrow-jet, accurate or compressed plasma" [4]. In the second option, it can be used as an additional measure to improve the efficiency of GVS in traditional plasma torches in order to ensure the precision quality of metal cutting.

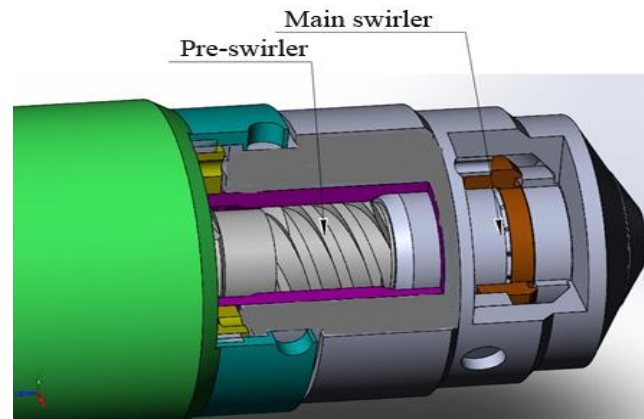

Figure 3. Constructive scheme of the plasma torch with two swirlers in the gas-vortex stabilization system

To assess the uniformity of the gas flow distribution, the authors proposed two methods depending on the hardware capabilities of the software and the required accuracy of calculations. A simplified version of the estimation (at the limited resources) involves the calculation of the PFG flow velocities in 4 symmetrical points in the selected plasma torch cross section, with one of the points selected opposite the point of gas injection into the expansion chamber (Fig.4, a). In this case, it is possible as a criterion for the uniformity degree in the cross section of GAP to use a velocity ratio $XI=V1/V2=V1/V3=V1/V4$ (Fig.4) [2]. However, there is an error of estimation due to the probability of missing the maximum and minimum deviations from the average values of the velocity in this section with its probable irregular distribution. In this regard, it is more objective to estimate the uniformity by the calculation method over the entire perimeter of the control plane. It is obvious that in this case, for the correctness of the comparison, it is necessary to calculate the velocities along the equidistant ring trajectory from the plasma torch axis (along the middle line of the passage section). At the same time, however, the problem to choose the criterion of the uniformity of the gas flow distribution arises.

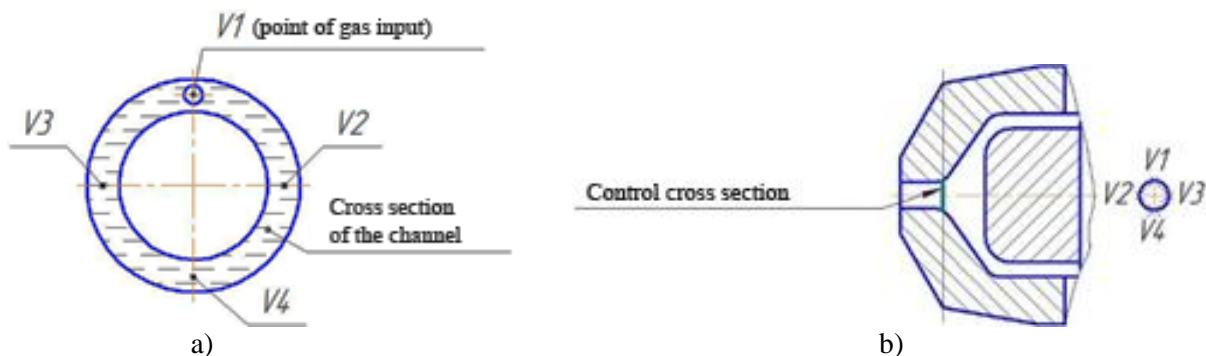
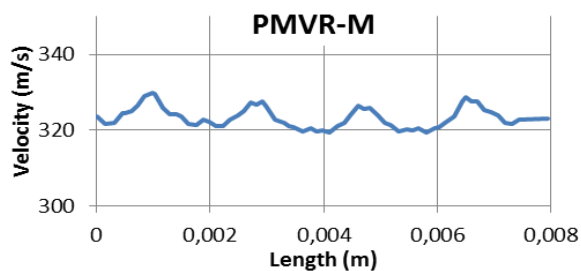

Figure 4. The location of points for the PFG velocities calculation: (a) in the cross section of the GAP channels, (b) in the control plane of the nozzle unit.

In order to solve the set tasks there were conducted the investigations of the uniformity of the gas flow distribution in the control section for 3 plasma torches – basic PMVR-M, the upgraded single-flow PMVR-2M and PMVR-5.3 with 2 swirlers in the system of gas-vortex stabilization. The calculations were performed under the same technological conditions (the pressure of PFG at the entrance to the plasma torch $P=5$ atm, the flow rate of PFG $Q=0.011$ kg/s) by the SolidWorks software with Flow Simulation application. The velocity calculation was performed along the middle line of the control section, the diameter of which was determined by the size of the nozzle outlet of plasma torch. The number of calculated points along the perimeter depended on the parameters of the computational grid, which were determined automatically by the software (from 40 to 200 points depending on the analysis tasks). To assess the effect of the plasma arc on the uniformity of the gas flow distribution, a comparative calculation of the velocities in the control plane of plasma torches in the absence of arc and in the conditions of the nozzle channel heating by plasma arc was performed. Estimate the temperature for air plasma cutting in the calculations was adopted on the bulk temperature of the arc $\approx 7\,000$ K for the arc diameter of 2 mm).

3. Results of research and their discussion

The results of velocity calculations in the control sections are presented at Fig.5. The obtained results confirm the conclusions made earlier by the authors about the influence of the GAP design on the gas-dynamic parameters of the PFG flow in the electric arc chamber of the plasma torch. Under the same conditions at the entrance to the plasmatron, the fixed velocities in the control section of the plasmatron PMVR-2M are 20%, and in PMVR-5.3 – 70% lower than of the basic PMVR-M. This result is probably due to two reasons. The first is related to the structural differences of the nozzle used in the considered plasma torches (the output diameter, the length of the cylindrical part of the output channel of the nozzle). The second reason is gas-dynamic losses by GAP of the plasma torch, where the greatest contribution is made by the swirler (up to 40% of the total amount of pressure losses [2]). It should be noted in this regard that the most effective operation of the plasma torches occurs under certain regimes determined by experiment, and, consequently, the presented results should indicate objective differences in the optimal performance ranges for each of the analyzed plasma torches.



a) no arc (64 points, $h = 0.15$ mm)

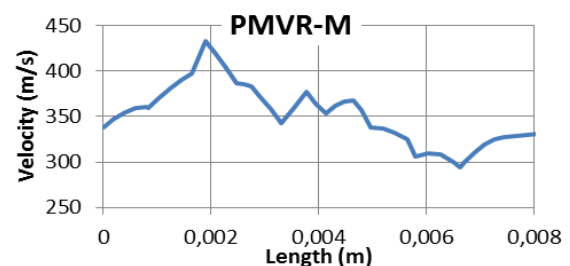

b) heating by plasma arc (41 point, $h=0,2$ mm)

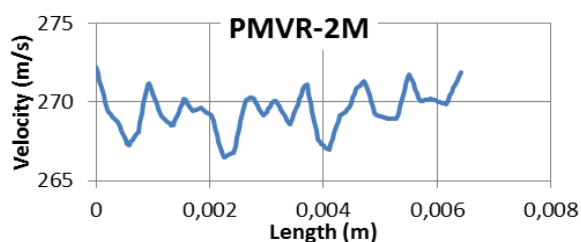

c) no arc (200 points, $h = 0.03$ mm)

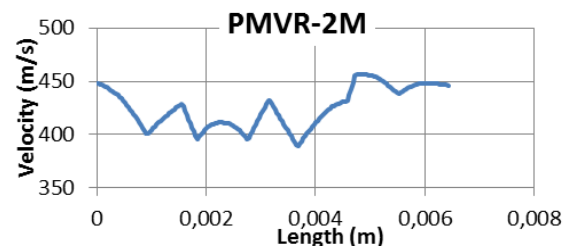

d) heating by plasma arc (200 points, $h = 0.03$ mm)

e) no arc (48 points, $h = 0.09$ mm)f) heating by plasma arc (124 points, $h = 0.03$ mm)

Figure 5. Velocity distribution in the control plane of the plasma torches (h - parameter of discretization)

Another important consequence of the obtained results analysis is the revealed effect of plasma arc on the velocity of PFG in the control section. It is obvious that at velocity of 150-300 m/s in the nozzle unit, the residence time of the gas in the arc combustion area from the cathode end to the entrance to the nozzle channel is from 10 to 100 μ s, which is clearly not enough to heat the entire flow (this effect is used to protect the channel walls from thermal influence). Nevertheless, the results indicate a small heating of the gas at the inlet to the channel and the velocities increase due to this heating in the points of the control section (in the plasma torch PMVR-M – about 15%, in PMVR-2M – by 55% , in PMVR-5.3 – by 40%). Such differences are obviously also due to the design features of the nozzle units of the analyzed plasma torches, which affect the nature of PFG interaction with the plasma arc. It should be noted that presented in Fig.6 the results of velocity calculations in the nozzle channel and at the outlet of the plasma torch PMVR-5.3 indicate the effective heating of the gas in the nozzle channel and obtaining at the outlet a high-energy flow with velocities of the order of 500-600 m/s for the kinetic effect on the cut metal.

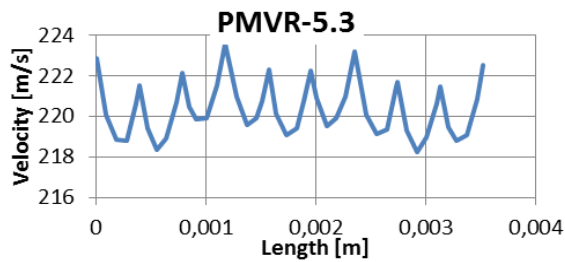
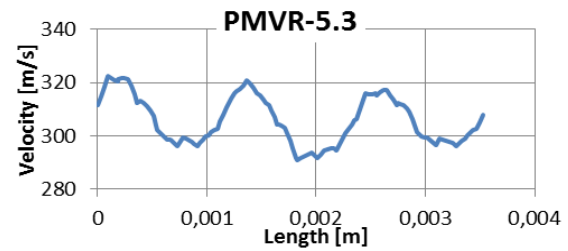
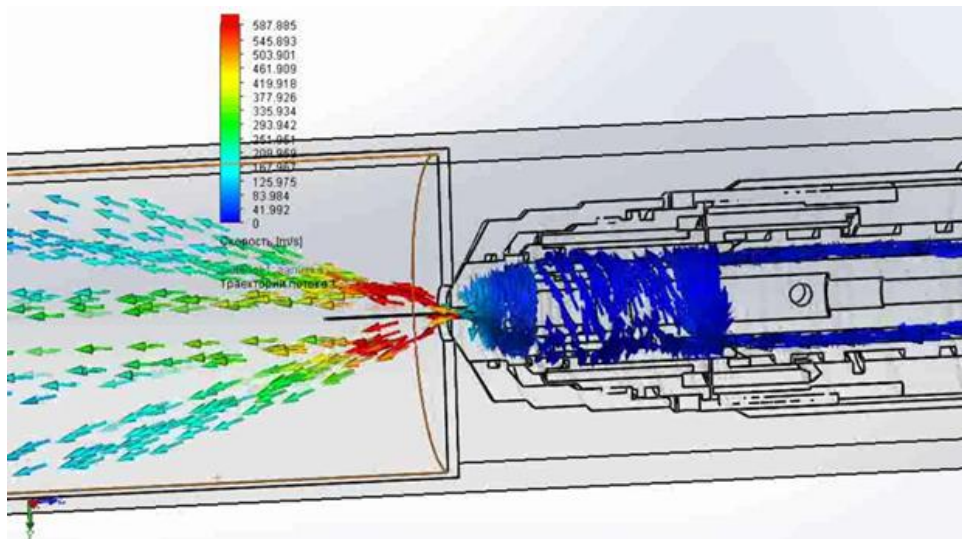

Figure 6. The velocity distribution in the GAP and plasma jet of plasma torch PMVR-5.3

In order to find the criterion for estimating the degree of the flow distribution uniformity in the analysis of a large number of control points, the obtained velocity distributions for different plasmotrons were analyzed by statistical methods. A statistical hypothesis was made that the presented velocity dependences are subject to either the normal or the uniform distribution law of random variables. However, verification of hypotheses by Pearson's χ^2 gave her not to a statistically significant

confirmation. It was not confirmed in the analysis of other speed distributions and in the change of frequency calculation intervals. For this reason, the processing presented in Fig.5 results as criteria were considered often used in the processing of large arrays of random variables parameters:

1. Scope of variation $R=V_{\max}-V_{\min}$,
2. Ratio of variation $L=V_{\max}/V_{\min}$,
3. Average linear deviation (ALD): $a=\sum_{i=1}^n |V_i - \bar{V}|/n$,
4. Standard deviation (SD): $S=\sqrt{\sum_{i=1}^n (V_i - \bar{V})^2/n}$,
5. Coefficient of variation $F=S/\bar{V}$.

For large sample sizes (in our case $n>40$) $S\approx\sigma$, were σ - dispersion of the random variable. The results of calculations of these parameters are presented in the table.1.

Analysis of the results, presented in the table.1, indicate a statistically significant increase in the efficiency of gas-vortex stabilization (uniformity of the velocity distribution) achieved in the modernized plasma torch PMVR-2M and PMVR-5.3 compared with the basic plasma torch PMVR-M. This conclusion is confirmed by comparing all the parameters presented for the analysis (R, L, a, S and F). When choosing a single criterion for the effectiveness of GVS, in the opinion of the authors, we should focus on the coefficient of variation F, which gives the expressed percentage of the ratio of the SD (dispersion) to its average value in the analyzed sample. This parameter is easily calculated, for example in Excel, where there is a built-in SD calculation function.

Table1. The results of statistical processing of the velocity distribution of the plasmatrons

Type of plasma torch	Heating conditions	Statistical parameters							
		V_{\max} , m/s	V_{\min} , m/s	\bar{V} , m/s	$R=V_{\max}-V_{\min}$, m/s	$L=V_{\max}/V_{\min}$	a (ALD), m/s	S (SD), m/s	F (%)
PMVR-M	no arc	323.4	319.6	330.0	10.4	1.03	2.3	2.8	0.9
	with the arc	353.0	295.0	433.0	138.0	1.47	26	33	9.3
PMVR 2M	no arc	269.4	266.6	272.2	5.6	1.02	0.9	1.2	0.4
	with the arc	425.0	389.0	457.0	68.0	1.02	17	19	4.5
PMVR 5.3	no arc	220.5	218.2	223.6	5.4	1.18	1.2	1.4	0.6
	with the arc	306.1	290.9	322.2	21.3	1.11	7.8	8.8	2.9

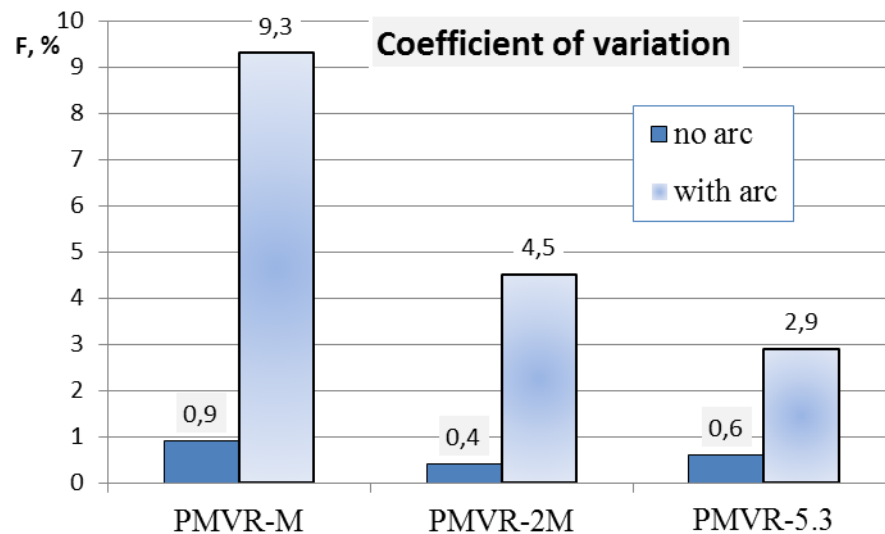

Figure 7. The coefficients of variation of the velocity in the control plane of a plasma torch

4. Conclusions

The analysis of the selected criterion F shows an increase of the GVS efficiency by 1.5-2 times on the "cold" gas (without heating by plasma arc) and 2-3 times at heating by plasma arc in the new plasma torches in comparison with the basic one (Fig.7). The presented results of calculations show, in addition to velocity increase, the effect of the plasma arc temperature on the uniformity of the PFG flow distribution. In plasma torches PMVR-M and PMVR-2M observed increase in the coefficient of variation of about 10 times, and in PMVR-5.3 – about 5 times, which also indicates the constructive advantages of the proposed system of gas-vortex arc stabilization for plasma torches, working by the "narrow-jet plasma" technology.

References

- [1] Anakhov S V Principles and methods of designing in electropasma and welding technologies, *RSVPU, Yekaternburg*. p 144, 2014
- [2] Anakhov S V, Pykin YU A, Matushkin A V Investigation of systems for gas vortex stabilization of plasma torches *J Welding International*, Vol 30, **Issue 4**, p. 310-314, 2016
- [3] Pyekin Yu A, Anakhov S V, Matushkin A V *Patent for the invention of "Plasmatron"* №. 2584367 RU C1 11.03.2015 (published 20.05.2016)
- [4] Anakhov S V, Pykin Yu A, Matushkin A V Narrow Jet Plasma as the Energy Efficient and Safe Technology for Metal Cutting *J Solid State Phenomena (Material Science Forum)*, **Vol 870**, p. 523-527, 2016